

Customized High Pressure Vertical Centrifugal Pump Stainless Steel Multistage

Our Product Introduction

Basic Information

- Place of Origin: Sichuan, China
- Brand Name: horizontal-slurrypump.com
- Certification: ISO9001
- Model Number: OEM
- Minimum Order Quantity: 1 set
- Price: USD 500-5000/set
- Packaging Details: free fumigation export wooden box packaging
- Delivery Time: 25 working days after receiveing advance payment
- Payment Terms: L/C, D/A, D/P, T/T, Western Union, MoneyGram, Paypal
- Supply Ability: 300 sets per month



Product Specification

- Theory: Centrifugal Pump
- Max Flow: 450m3/h
- Max Head: 120m
- Speed: 1500rpm
- Voltage: Requirements
- Warranty: 1 Year
- Flange: Customized
- Highlight: **vertical submerged centrifugal pump**



for more products please visit us on horizontal-slurrypump.com

Product Description

Factory Customized High Pressure Stainless Steel Pump Vertical Multistage Centrifugal Pump

Product Description

WDL-series pump is anti-abrasive and anti-corrosive vertical submerged centrifugal pump, which is designed according to multiphase flow theory and practice experience. WDL-series single stage single-suction pump is applicable to convey easy crystal medium containing solid particles, featured by excellent performance, advanced structure, good anti-cavitation properties, strong bearing, stable operation, easy maintenance and long service life.

Product Data

Structure: single-stage pump
Capacity: 8 ~ 450m³/h
Head: 15 ~ 120m
Maximal Efficiency: 70%
Diameter:200mm~470mm
Pressure:1.6MPa
Temperature: -50°C~80°C
Motor Power:5.5~160KW
RPM: 1450 r/min

Technical Parameter

model	flow (m ³ /h)	Head (m)	Rotating speed (r/min)	Highest efficiency (%)	pump head weight KG	Submerged depth mm	Shaft component
40WDL-250	8-20	15-28	1450	39	620	1300/1000	100
40WDL-310	8-40	23-42	1450	45	692	1300/1000	100
40WDL-350	8-45	35-54	1450	37	870	1300/1000	120
50WDL-250	10-30	15-28	1450	40	642	1300/1000	100
50WDL-310	15-60	25-42	1450	45	705	1300/1000	100
50WDL-350	15-70	35-54	1450	50	886	1300/1000	120
50WDL-400	20-75	50-75	1450	45	961	1300/1000	120
65WDL-250	30-70	15-28	1450	48	652	1300/1000	100
65WDL-310	30-90	25-40	1450	57	905	1300/1000	120
65WDL-350	40-100	35-54	1450	59	915	1300/1000	120
65WDL-400	50-120	45-75	1450	55	1008	1300/1000	120
65WDL-450	50-120	70-95	1450	52	1075	1300/1000	120
80WDL-250	70-100	15-25	1450	61	652	1300/1000	100
80WDL-310	70-120	25-40	1450	62	935	1300/1000	120
80WDL-350	70-160	35-52	1450	65	940	1300/1000	120
80WDL-400	70-160	50-75	1450	62	1068	1300/1000	120
80WDL-450	70-160	70-95	1450	60	1100	1300/1000	120
100WDL-310	100-150	20-38	1450	65	960	1300/1000	120
100WDL-350	100-220	35-50	1450	65	970	1300/1000	120
100WDL-400	100-220	40-72	1450	65	1125	1300/1000	120
125WDL-310	120-260	18-36	1450	67	1025	1300/1000	120
125WDL-350	120-300	35-50	1450	68	1035	1300/1000	120
125WDL-400	140-350	45-70	1450	70	1206	1300/1000	120
125WDL-450	150-360	65-90	1450	67	1497	1300/1000	140
150WDL-310	200-400	18-35	1450	72	1127	1300/1000	120
150WDL-350	200-450	25-48	1450	75	1175	1300/1000	120
150WDL-400	200-450	40-65	1450	73	1668	1300/1000	140

Features

WDL series anti-corrosion and wear-resistant horizontal centrifugal pump adopts CAD modular structure design, more than 20 models, only 5 bearing bodies. The parts of the same series have great interchangeability. The inlet and outlet flanges of WDL pumps follow the standard of HG20592-2000PN16Mpa, and different flange standards can be implemented according to user requirements.

The bearing is grease-lubricated, equipped with large grease storage space. The two ends of the lower bearing are respectively sealed with lip-type oil-resistant rubber and oil retaining disc. The upper ends of the upper bearing are respectively sealed with lip-type oil-resistant rubber and felt, which can make the grease remains clean

The whole unit is installed on the base. The base is made of integral thick steel plate with good rigidity, high strength, anti-deformation and easy installation.

Installation Dimension

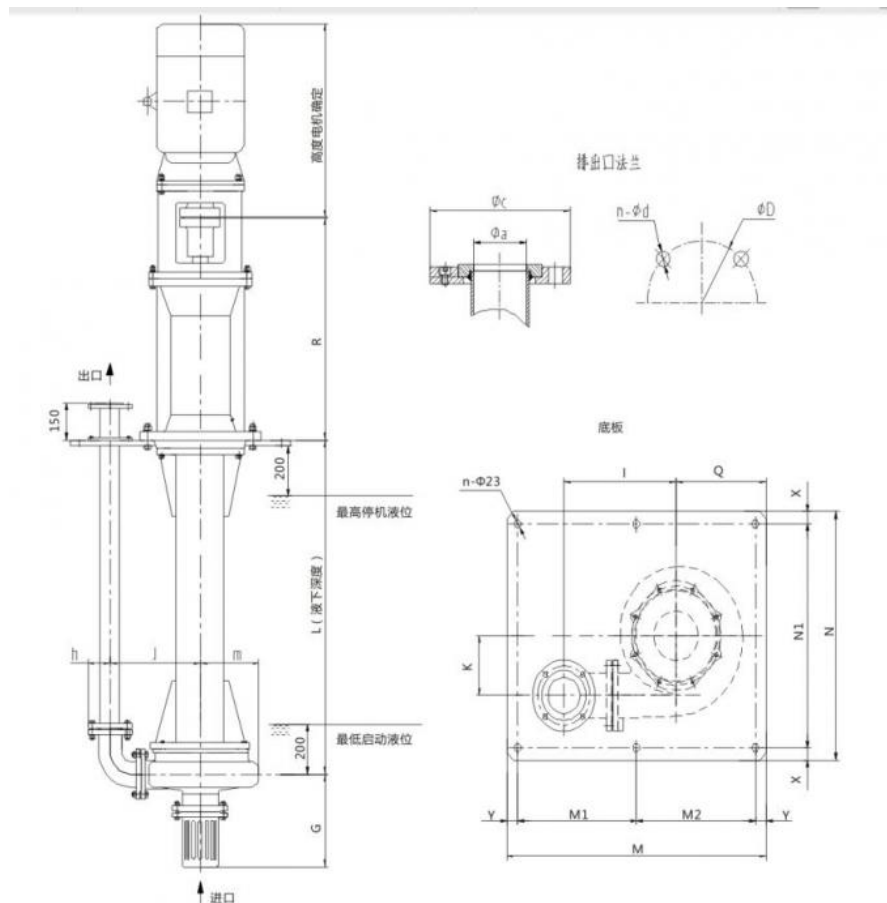

Product Picture





Service

- * Quick reply
- * Professional engineer.
- * Good package
- * Fast after-service

 **ROMAN Beijing Silk Road Enterprise Management Services Co.,LTD**

 0086-17773109286

 jeffreyth@slurrypump.com

 horizontal-slurrypump.com

Floor 5, 2nd Building, Zhonglu Industrial Zone, Shenzhen City, Guangdong Province China (Mainland)